



BRADNAM'S
AWNING
WINDOWS



Bradnam's
windows & doors

Awning Window Range

If you want windows that can provide natural ventilation year-round and invite natural light into your home, Bradnam's **awning windows** are exactly what you've been looking for.

Essential Awning Windows

'Essential' awning windows are our standard aluminium awning window product. Packed full of benefits and features, they've been designed with modern living in every Australian climate firmly in mind. Our Essential awning windows are available in a range of standard configurations as well as custom designs.

Signature Awning Windows

Our 'Signature' awning window range is a high-quality collection that includes both standard and oversize options so you can find the perfect window to suit your home's design and aspect. They can be combined with fixed windows to create feature windows or maximise natural light and your view.

Commercial Awning Windows

Bradnam's 'Commercial' collection includes aluminium awning windows in small and large sizes. Aesthetically appealing and heavy duty, they're specifically designed for commercial environments or unique, high-end homes.

Performance Parameters

| | Essential | Signature | Commercial |
|---|------------|------------|------------|
| Frame size | 52mm | 100mm | 100mm |
| Maximum panel height | 2400mm | 2400mm | 2400mm |
| Maximum panel width | 2150mm | 2750mm | 2750mm |
| Maximum window width | 5340mm | 5350mm | N/A |
| Maximum panel weight | 74kg | 74kg | 74kg |
| Maximum water rating | 600Pa | 600Pa | 600Pa |
| Maximum wind rating | 4500Pa ULS | 4500Pa ULS | 4500Pa ULS |
| Maximum glass thickness (single glazed) | 12.76mm | 12.76mm | 12.76mm |
| Maximum glass thickness (double glazed) | 24mm | 24mm | 24mm |
| Maximum acoustic rating | Rw37 | Rw38 | Rw38 |
| Maximum bushfire rating | BAL 40 | BAL 40 | BAL 40 |
| Lowest U-value (single glazed) | 4.9 | 5.4 | 5.6 |
| Lowest U-value (double glazed) | 3.2 | 3.2 | 4.2 |

Note: Performance figures are independent of each other and subject to conditions. Contact a Bradnam's Windows & Doors representative to discuss your specific project requirements.

Features & Benefits

Essential . Signature . Commercial

Lifestyle & Comfort

- Stylish and ergonomic foldable handle
- Can be used as a kitchen splashback to bring in more light and ventilation

Optional

- Wide range of screening solutions are available
- Keys can be 'keyed alike' with Bradnam's doors for convenience*
- Openings can be restricted for upper storey windows

Design & Aesthetic

- Available in a range of lifestyle configurations
- Curtain-friendly design protects window furnishings from sharp edges
- Combine with fixed windows to create a feature wall
- Architectural symmetry with other Bradnam's windows and doors

Optional

- Create a Hamptons look with colonial bars

Performance & Reliability

- Fully compliant with relevant Australian Standards
- Chains are made of stainless steel, minimising the chance of corrosion happening
- High-quality seals provide superior protection against the elements
- Sashes are hung from a concealed heavy duty bar for superior stability

Optional

- Save on energy bills with double glazing
- Reduce outside noise by incorporating our Sound Smart™ system
- Twin chain winders enable effortless operation of large sashes
- Bushfire rated – certified up to BAL 40
- Suitable for cyclonic regions

- * Excludes cam handles, patio bolts and commercial hinged & pivot doors

+ Premium Feature

Commercial Only

- Glass can be replaced from the inside of the building – ideal for multi-storey projects



Smart Solutions

High Performance Windows and Doors

Essential . Signature . Commercial

Building in today's environment demands the need to satisfy energy efficiency, acoustics, security and bushfire requirements. Bradnam's **Smart Solutions** range is designed to augment all Essential, Signature and Commercial products to satisfy these needs.

Some of the possible benefits

- Cooler in Summer
- Warmer in Winter
- Enhanced UV protection
- Reduce outside noise
- Save on energy bills

Performance comes from **more than just glass**

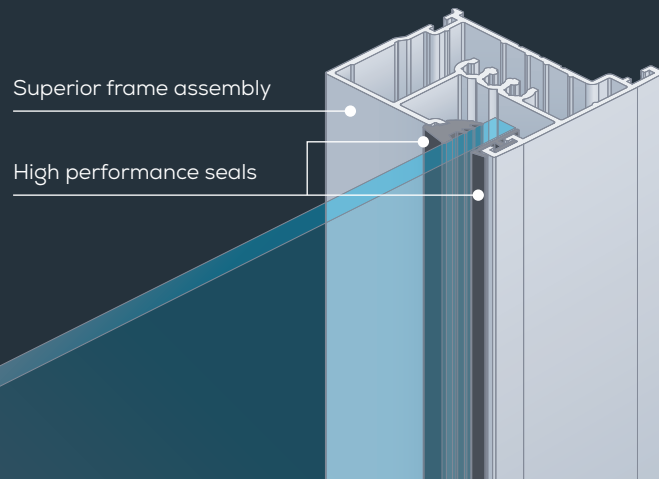

As the market leader in Australia for aluminium and glass building products, Bradnam's have developed its range of **Smart Solutions** to meet all high performance requirements.

+ Premium Smart Solution

Double Glazed

Year-round Comfort

- Acts as extra insulation by limiting the flow of hot or cold air in and out of your home
- Helps maintain comfortable temperatures inside across all seasons

Energy Reduction

- Reduce reliance on air conditioning and heaters – lowering electricity bills
- Consume less energy for a smaller carbon footprint

Noise Reduction

- Reduce outside noise – creating a quiet haven inside your home

Safety

- Extra strong resistance to unwanted attacks by intruders

Climate Control Solutions

Solar Comfort™

Year-round Comfort

- Designed to reflect heat away in summer and keep heat inside during winter
- Enjoy the ideal temperature in your home all year round – cooler in summer, warmer in winter

Energy Reduction

- Keep power bills down by reducing the need for additional heating and cooling
- Help save the environment by consuming less energy

Solar Block™

Cooler in Summer

- Minimise the flow of heat into your home – enjoy summer without feeling the heat
- Acts like a pair of sunglasses for your home, reducing glare by up to 78%

Energy Reduction

- Save on electricity bills by reducing the need for air conditioners
- Minimise your carbon footprint by consuming less energy

Specialty Solutions

Safety

Safety

- Effective, affordable barrier against forced entry
- Enjoy peace of mind knowing that your home has extra protection

Sound Smart™

Noise Reduction

- Reduce unwanted external noise – nearby traffic or noisy neighbours,

FlameShield™

Superior Bushfire Protection

- Meets Australian Standard AS3959:2009, which is aimed to reduce the risk of loss of life and property in bushfire prone areas

AWNING WINDOWS

Essential . Signature . Commercial

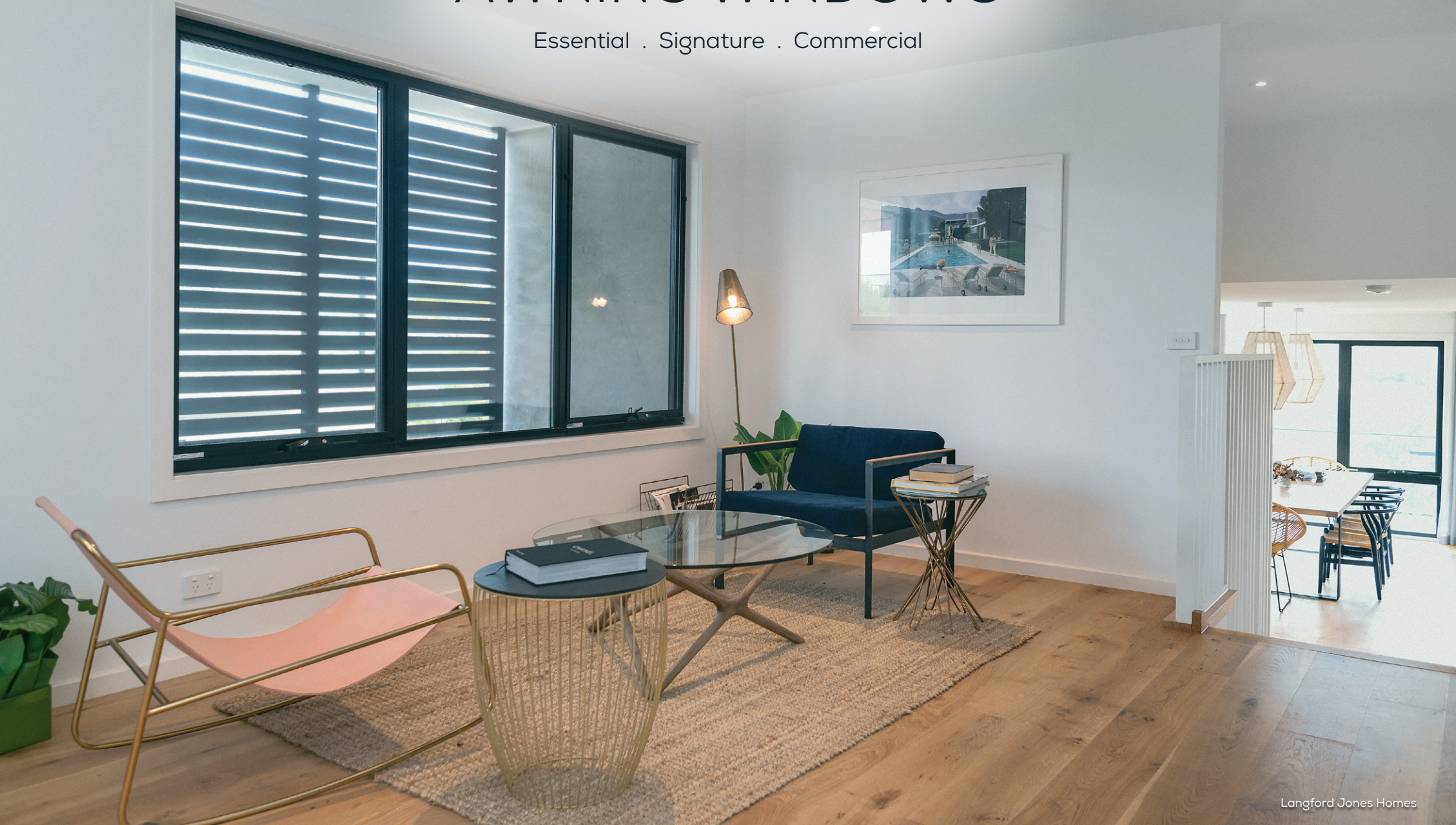

Winders

The winders displayed on this page are a guide only. Bradnam's recommend the viewing of an actual winder prior to order.

| Black Gloss | White | Ultra Silver |
|-------------|-------|--------------|
|-------------|-------|--------------|

| | | | |
|------------|---|---|---|
| ESSENTIAL | • | • | • |
| SIGNATURE | • | • | • |
| COMMERCIAL | • | • | • |

- ESSENTIAL
- SIGNATURE
- COMMERCIAL

Winders can be folded to minimise interference with window furnishings

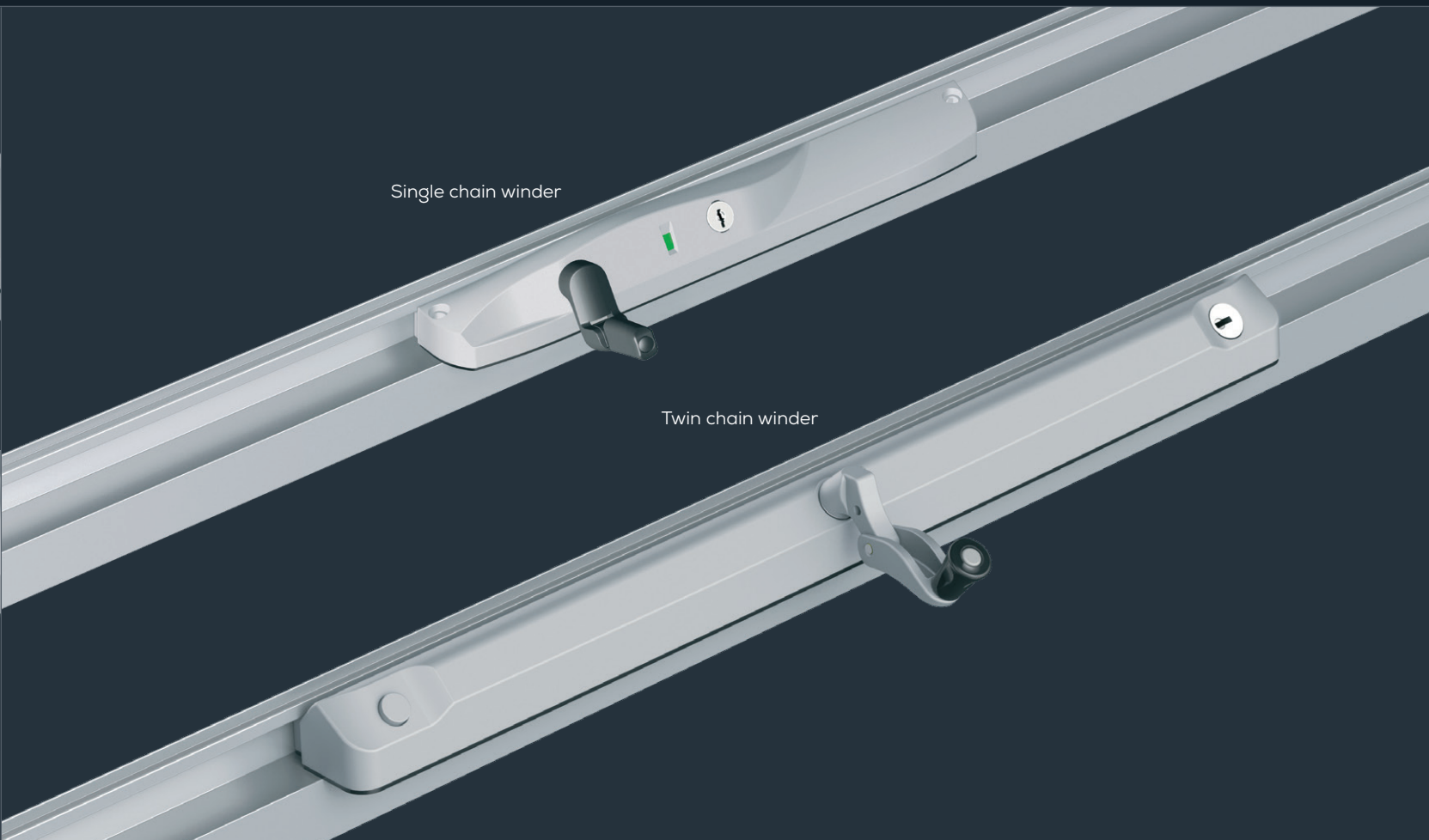

Single chain winder

Twin chain winder



VISIT US ON SOCIAL MEDIA

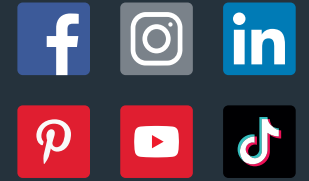

WINDOWS & DOORS

INSECT & SECURITY SCREENS

SHOWER SCREENS

MIRRORS & WARDROBES

GLASS SPLASHBACKS & SHELVING



Australian Owned & Made

Bradnam's products are proudly made in Australia and designed specifically to meet all Australian conditions.

Product availability, pricing, features, options, sizes, configurations and performance are subject to regional variations, design requirements and building codes.

Images are for illustration purposes only and may not accurately represent the product. Bradnam's Windows & Doors reserves the right to change, alter or delete any aspect of this product without notice.

We recommend visiting a Bradnam's showroom before ordering to view colour swatches, glass samples and actual products.



Bradnam's
windows & doors

Alphaline Homes



Bradnam's Windows and Doors . QBCC Act lic 58885
© Bradnam's Windows and Doors . v4 July 2024